

PE24

Through Beam Photoelectric Beam Sensor

Features

- 12-24V AC/DC Input Voltage
- 30 metres indoor and 10 metres outdoor range
- Rugged all weather design (IP-66)
- N.C./ N.O./ Common Relay Output
- Terminal block wiring connection
- Outstanding reliability and false alarm immunity
- PC Resin cover (Anti-UV)



Application

- Sliding Gates, Swing Gates or Garage Doors
- Overhead Doors, Conveyers or Door Entrance
- Boom Gates, Alarm System or Warehouse Monitoring

Description

The photoelectric beam works with any Elsema type automatic gate or door controller cards used on sliding, swing or roller doors. It is usually used as a safety device to control automatic gates and doors.

The PE24 works on infrared technology and is capable of switching loads of 1 Amp on 30 volts. Its low standby current consumption makes it ideal for automatic gates and doors operating on solar power.

Technical Data

Power Source	12 to 24 Volts AC or DC	
Current Consumption	Receiver	15mA when beam is broken, 30mA when beam is aligned properly.
	Transmitter	37mA
Response Time	100 millisecond	
Operation Indicator	Red LED (RX): On (when beam is broken), Green LED (Tx): ON	
Illumination	Lamplight<10,000lux; Sunlight <30,000lux	
Noise Resistance	1500Vp-p/1us	
Surge Resistance	2KV/1us	
Vibration Resistance	10-55Hz/1.5mm, 2 Hour in X.Y.Z. Phase	
Connection	Terminal Block	
Operating Temperature	-20°C to 60°C	
Relay Output	Common, Normally open or normally close.1A/120VAC	
Useable Operating Range	30 metres indoor and 10 metres outdoor range. Range will be reduced in bad weather, fog, dust etc.	
Dimensions	87 x 59 x 38mm.	

Internal View

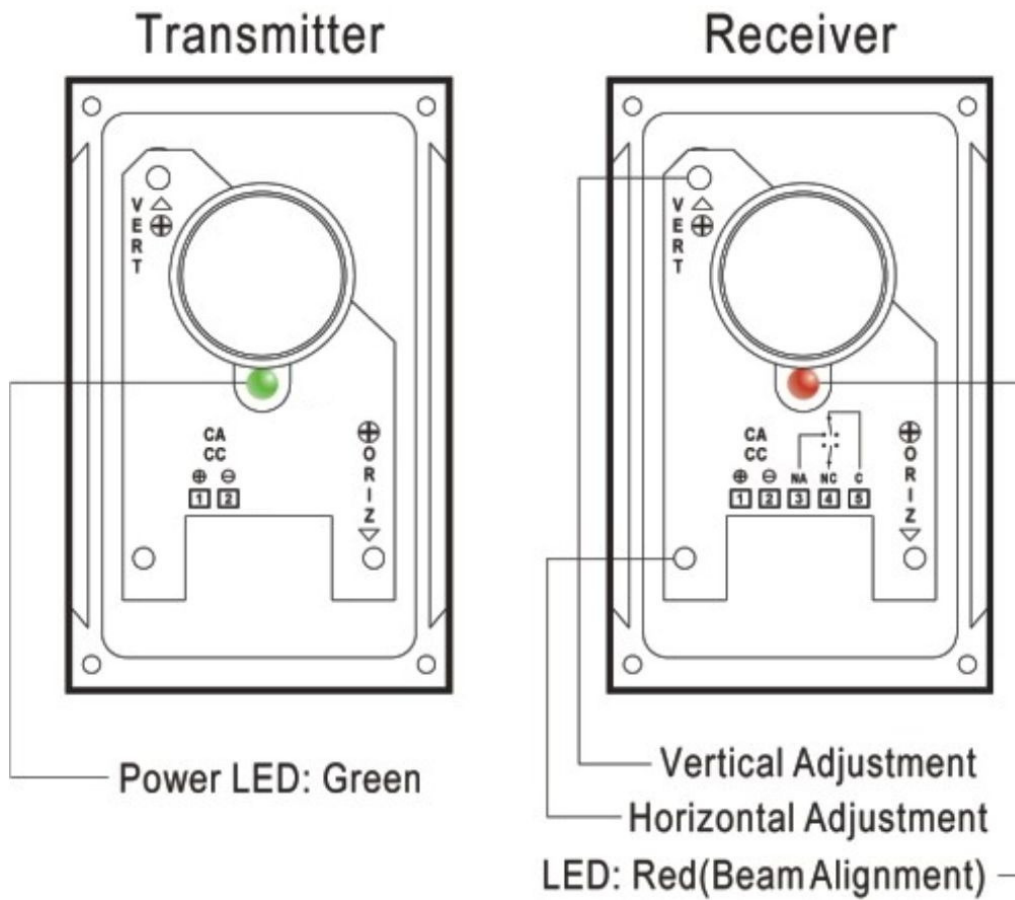

Wiring Diagram

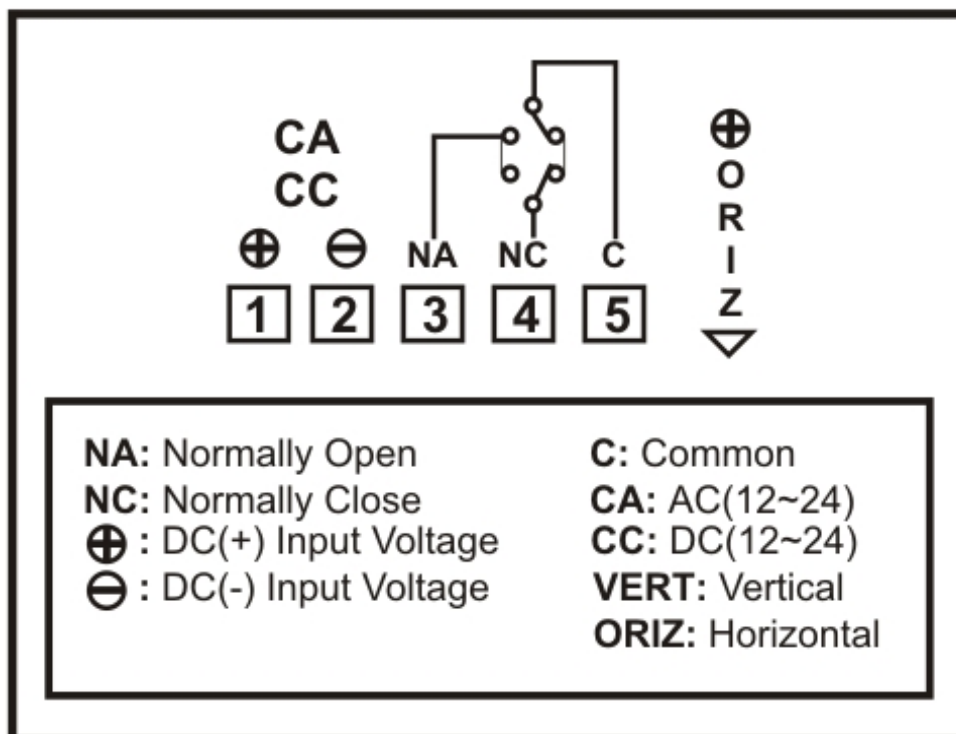

Standard Installation

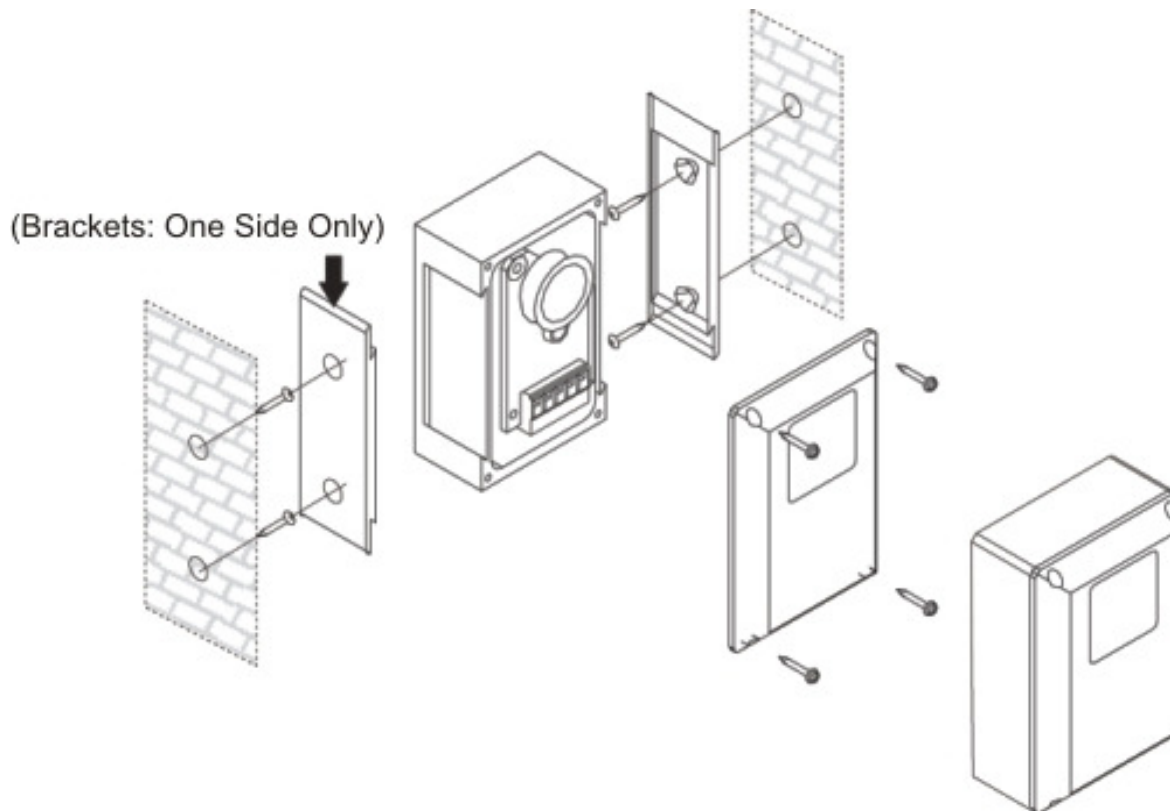

Dimension

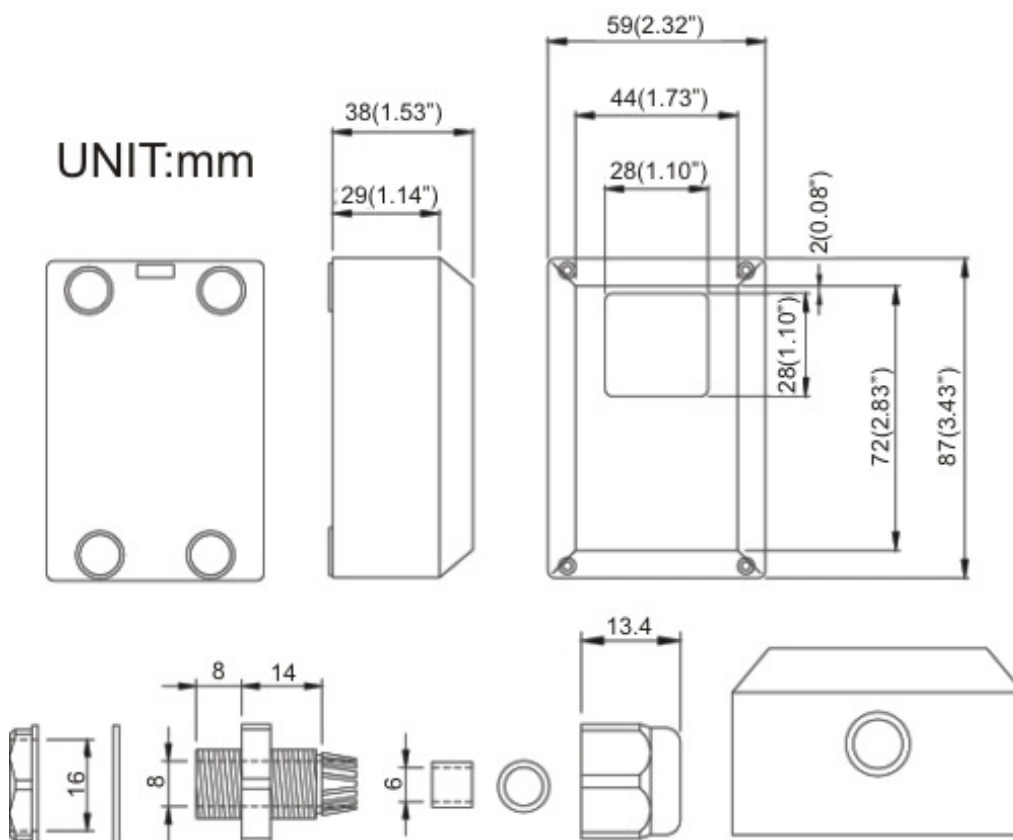

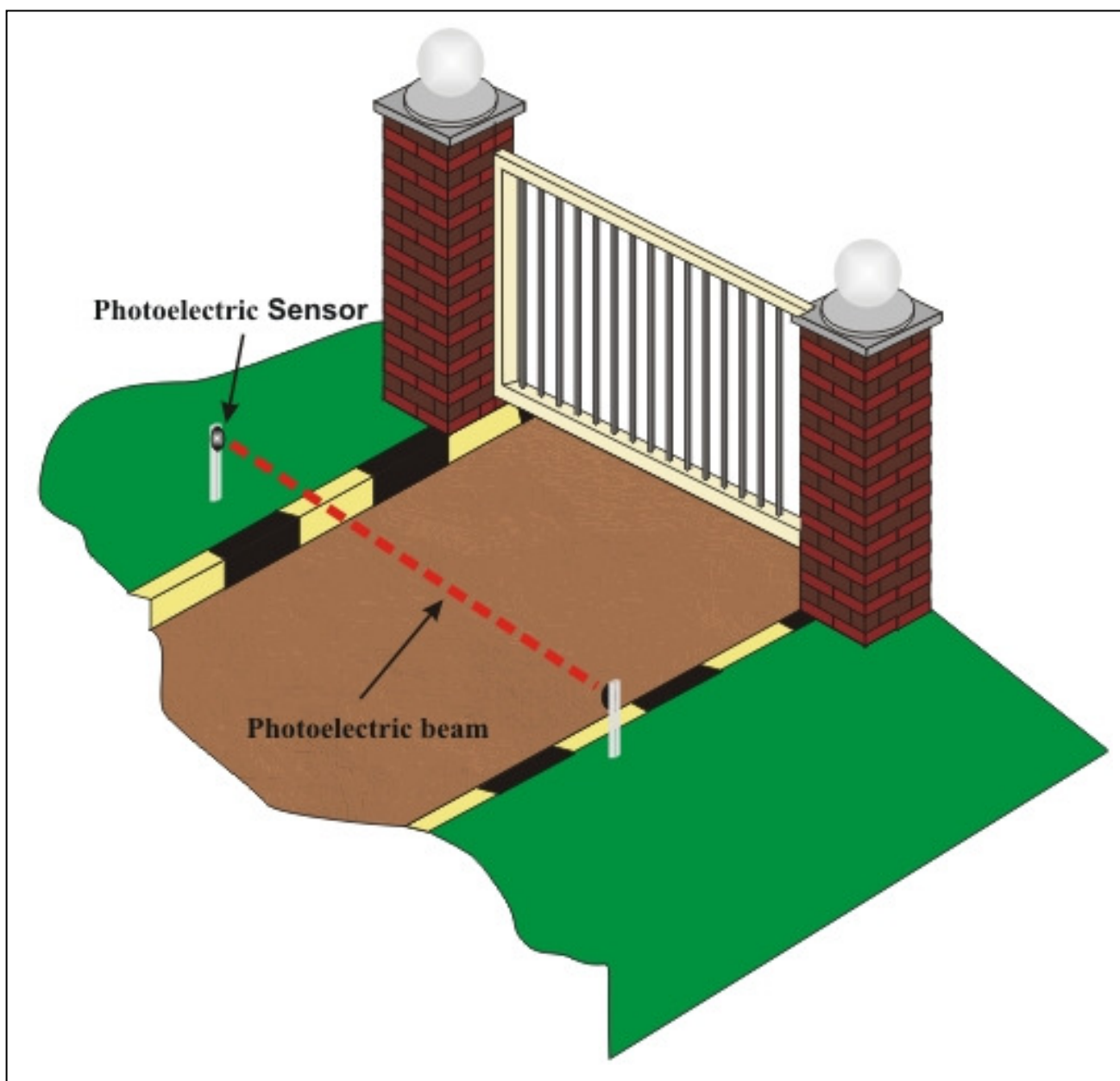
PE24 Application

Trouble shooting

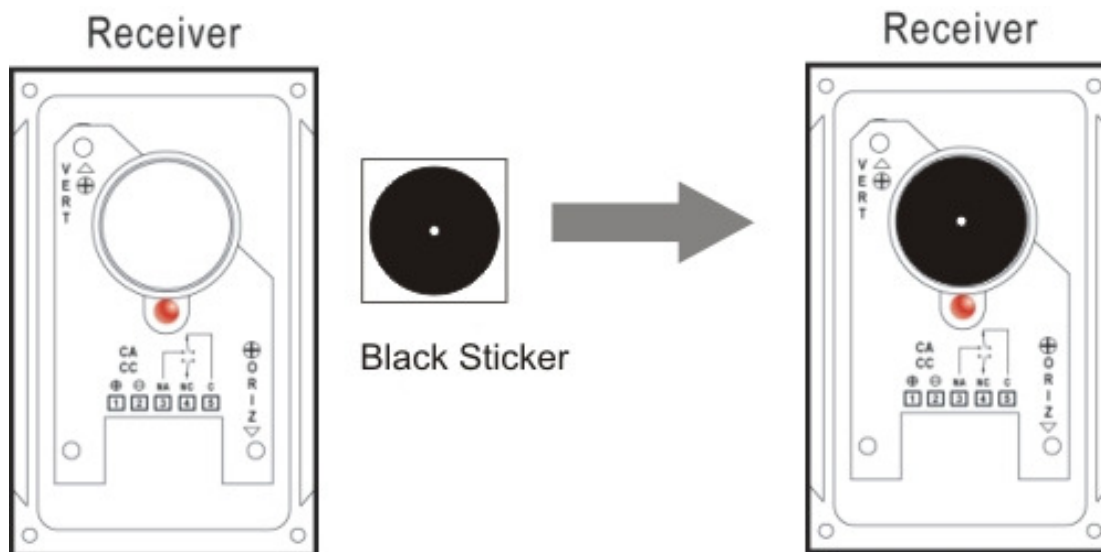

Use and stick the black round sticker onto the Receiver lens when more than one pair of PE24 photo sensors are used next to each other, in order to prevent intervention between the pairs.

It is also recommended to use stickers, when the distance between Rx and Tx is less than 3metres to achieve better and effective sensitivity.

Manufactured by

Elsema Pty Ltd
31 Tarlington Place, Smithfield
NSW 2164, Australia
Ph: 02 9609 4668
Fax: 02 9725 2663
Website: <http://www.elsema.com>

Distributed by

