

| REV. | DESCRIPTION | REVISED BY | DATE |
|------|---------------------|------------|-------|
| A | DESCRIPTION UPDATED | LL | 03/16 |

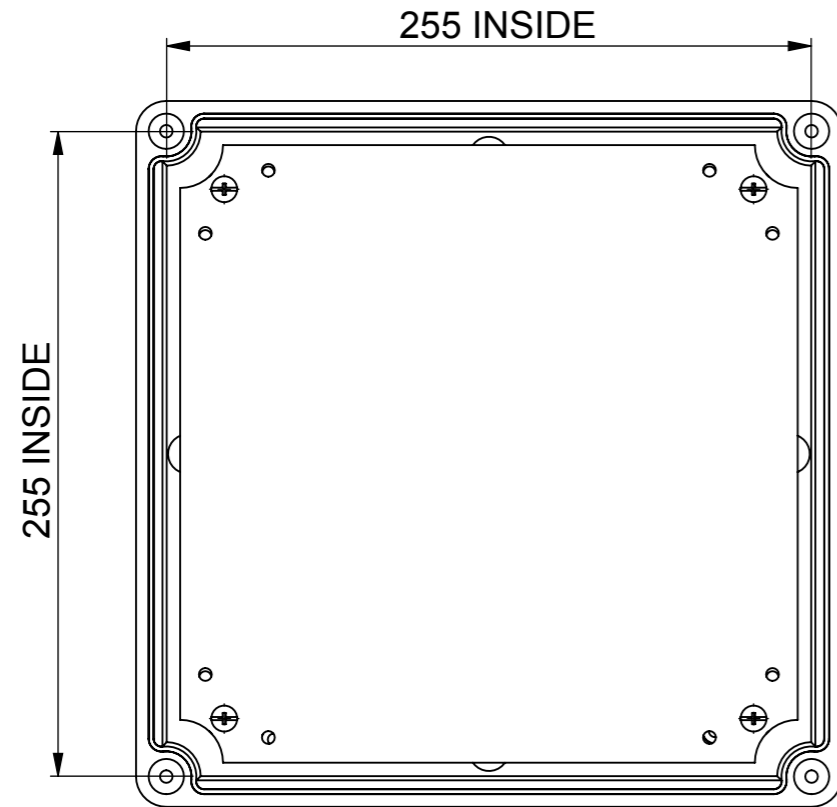

TOP VIEW (LID WAS HIDDEN TO SHOW INSIDE)

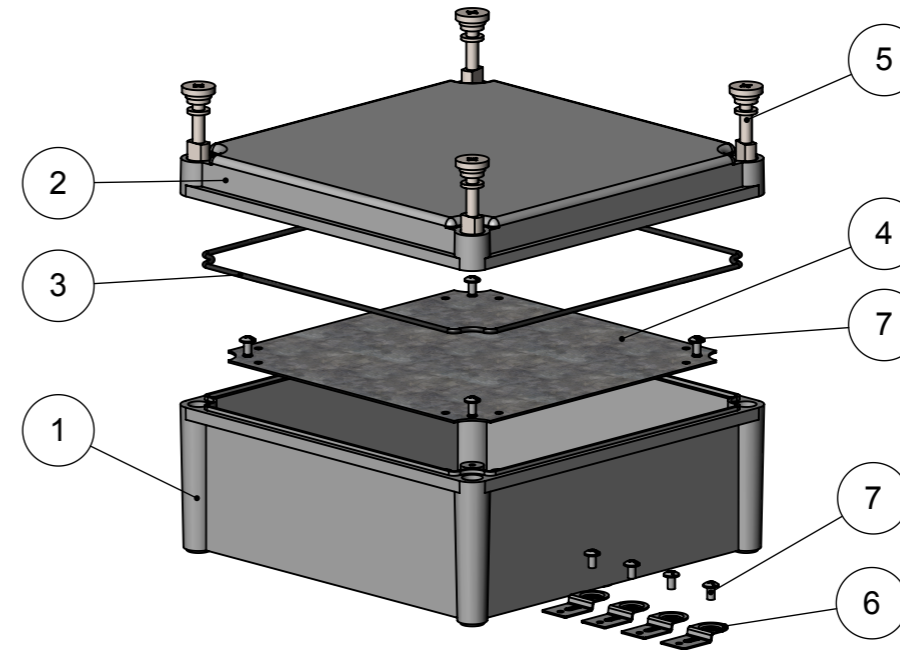

SCALE 1 : 5

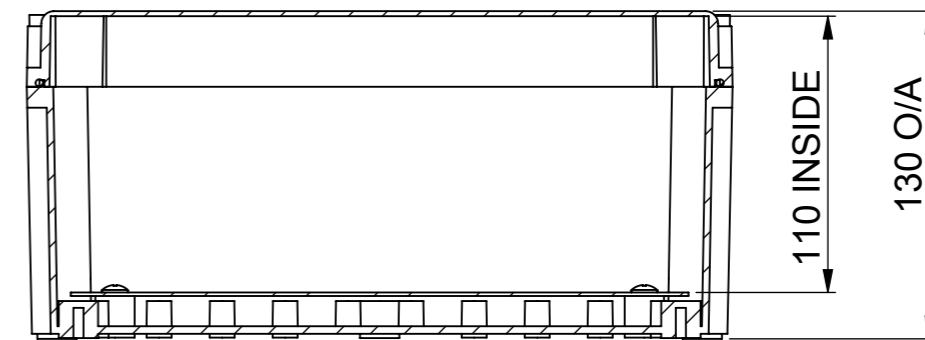

SECTION A-A

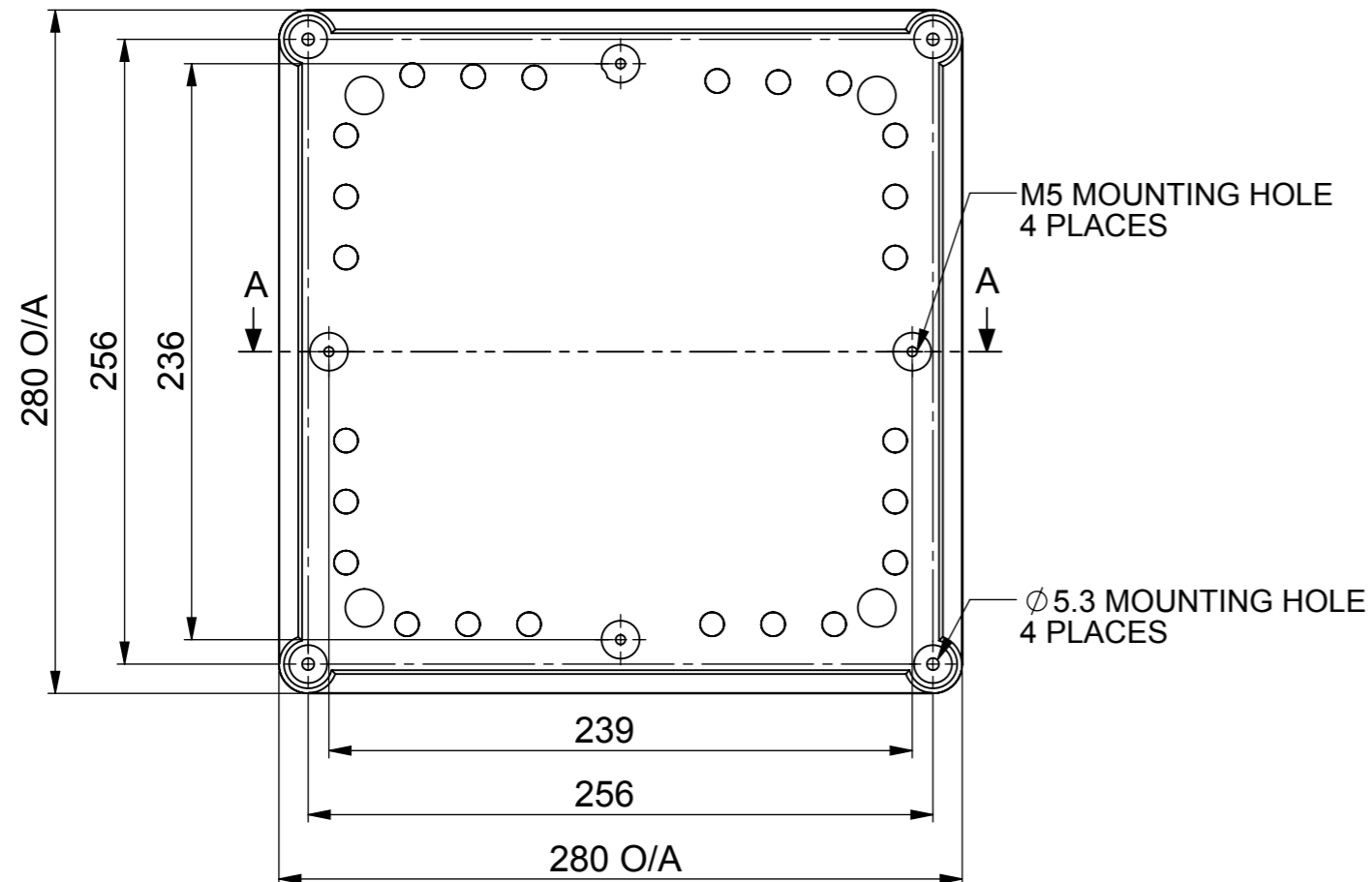

BACK VIEW

| 7 | SCREW M5X9 - PAN HEAD | SHEET 1 | ZINC PLATED | 8 |
|----------|-----------------------|--------------|------------------------|------|
| 6 | MOUNTING BRACKET | SHEET 2 | STAINLESS STEEL 1.0mm | 4 |
| 5 | LID SCREW | SHEET 1 | POLYCARBONATE (PC) | 4 |
| 4 | MOUNTING PLATE | SHEET 2 | GALVANIZED STEEL 1.4mm | 1 |
| 3 | SEAL | SHEET 1 | EPDM RUBBER | 1 |
| 2 | LID | SHEET 1 | POLYCARBONATE (PC) | 1 |
| 1 | LOWER CASE | SHEET 1 | POLYCARBONATE (PC) | 1 |
| ITEM NO. | DESCRIPTION | SHEET NUMBER | MATERIAL | QTY. |

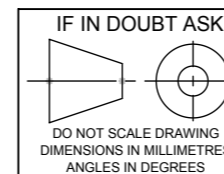

TOLERANCE
UNLESS OTHERWISE SPECIFIED

LINEAR x ± 1
x.x ± 0.5
x.xx ±

ANGULAR x ± 1
x.x ±

ELSEMA

© Copyright
ELSEMA PTY LTD
ABN: 77 001 562 563
31 Tarlington Place
Smithfield NSW 2164
Australia
Telephone (61 2) 9725 1180
Facsimile (61 2) 9725 2663

DRAWN:
L. LI

CHECKED:

APPROVED:

DATE:
06/05/2014

| | | | | |
|----------------|-------------------|--------------|---------------|-----------|
| MATERIAL: | SEE BOM | | | |
| FINISH: | | | | |
| DRAWING TITLE: | CASE C2828 | | | |
| SCALE: | PART No: | DRAWING No: | SHEET No: | REVISION: |
| A3 1:3 | C2828 | 10111 | 1 of 2 | A |

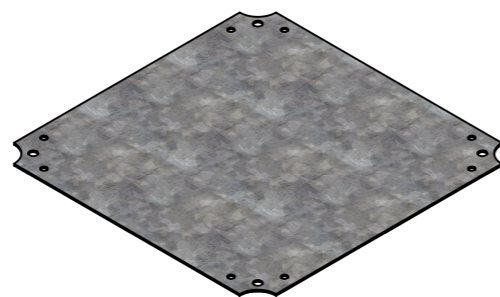

SCALE 1 : 5

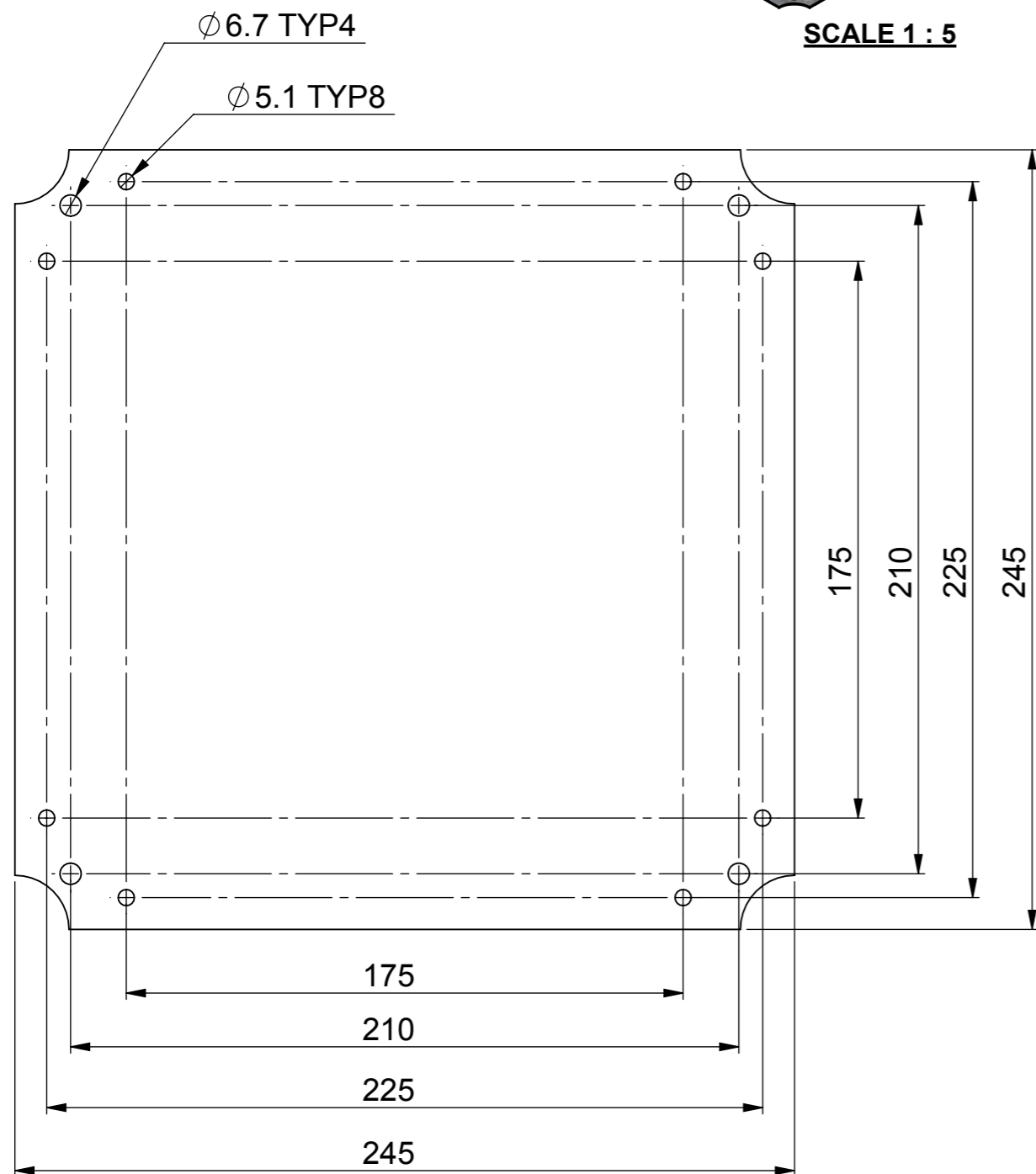

SCALE 1 : 2

ITEM NO.4: MOUNTING PLATE

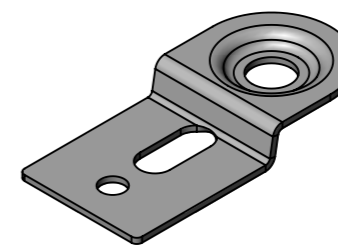

SCALE 1 : 1

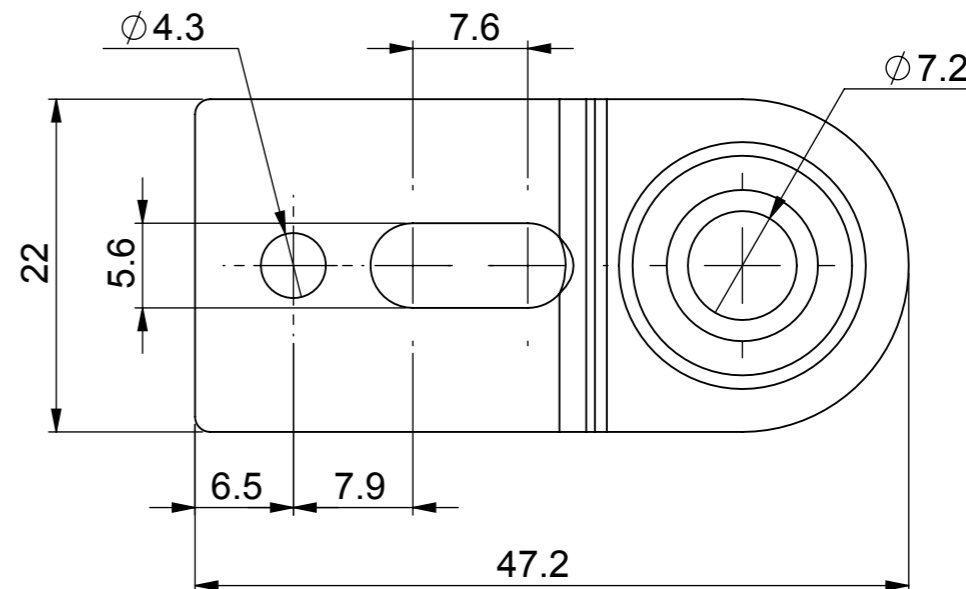
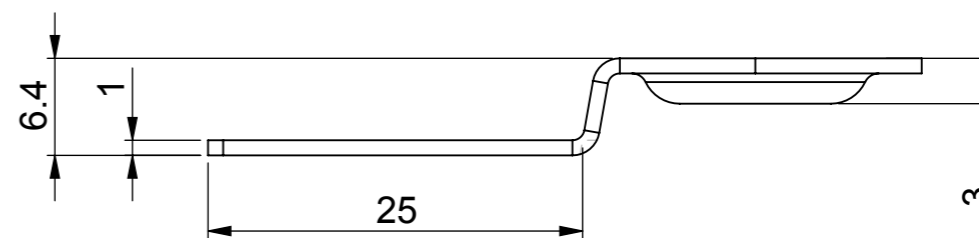

ITEM NO.6: MOUNTING BRACKET

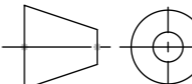
IF IN DOUBT ASK

 DO NOT SCALE DRAWING
 DIMENSIONS IN MILLIMETRES
 ANGLES IN DEGREES

TOLERANCE
 UNLESS OTHERWISE SPECIFIED
 LINEAR x ± 1
 x.x ± 0.5
 x.xx \pm
 ANGULAR x ± 1
 x.x \pm

ELSEMA
 © Copyright ELSEMA PTY LTD
 ABN: 77 001 562 563
 31 Tarlington Place
 Smithfield NSW 2164
 Australia
 Telephone (61 2) 9725 1180
 Facsimile (61 2) 9725 2663

DRAWN: **L. LI**
 06/05/2014
 CHECKED:
 APPROVED:

| | | | | | |
|----------------|----------|-------------------|---------------|-----------|--|
| MATERIAL: | | SEE BOM | | | |
| FINISH: | | | | | |
| DRAWING TITLE: | | CASE C2828 | | | |
| SCALE: | PART No: | DRAWING No: | SHEET No: | REVISION: | |
| A3 2:1 | | 10111 | 2 of 2 | A | |