

REV.	DESCRIPTION	REVISED BY	DATE

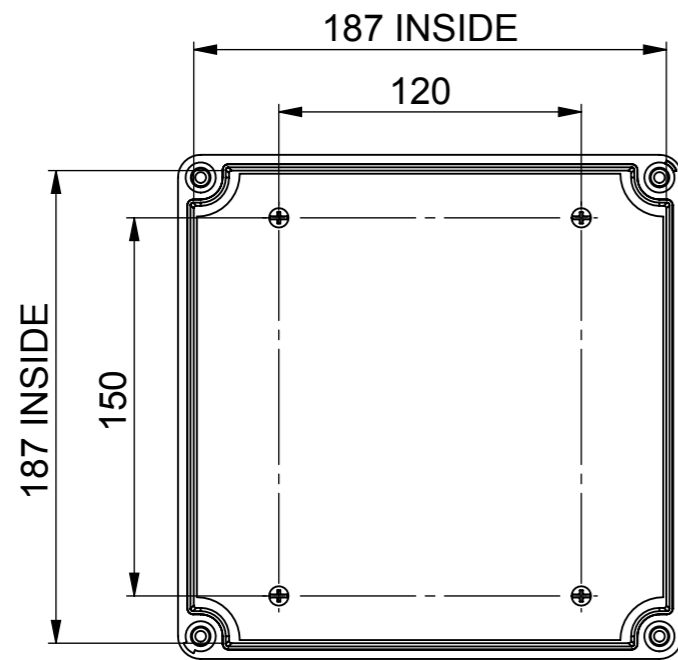

TOP VIEW (LID WAS HIDDEN TO SHOW INSIDE)

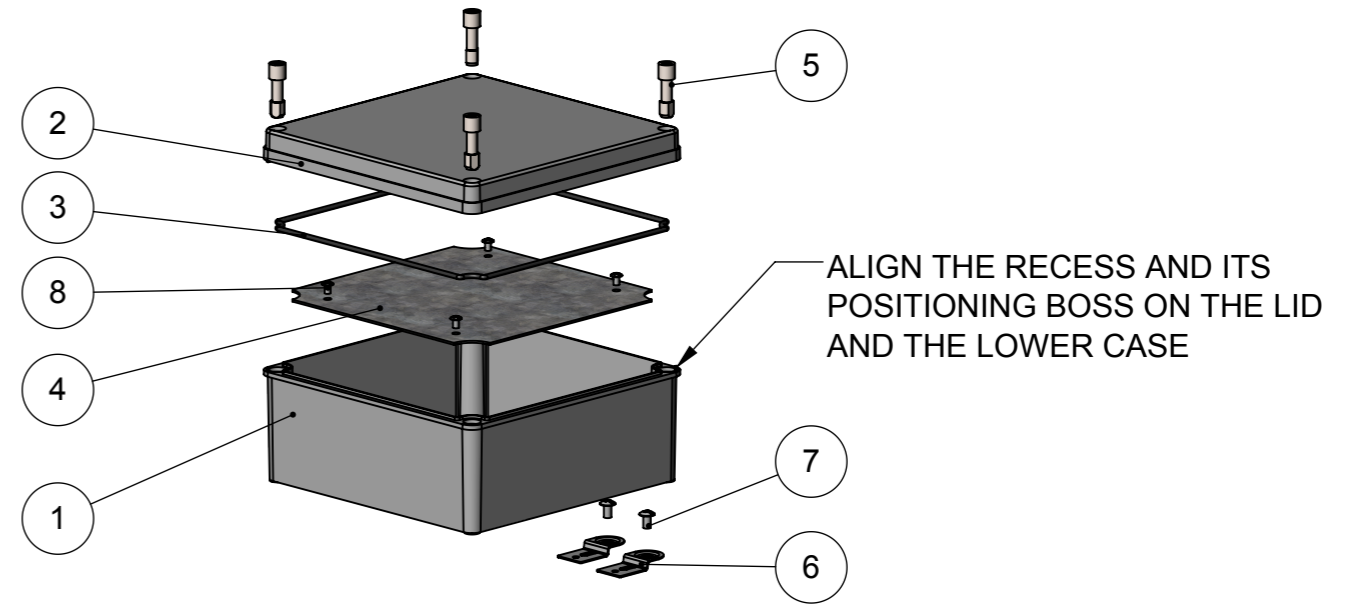

SCALE 1:5

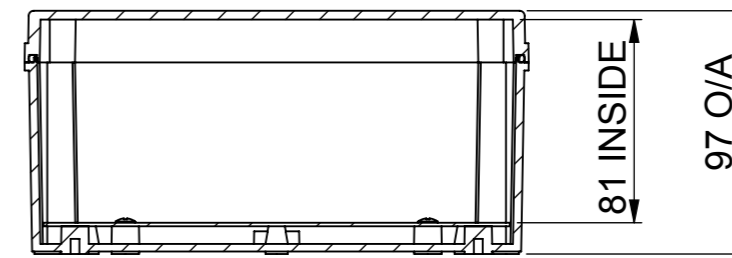

SECTION A-A

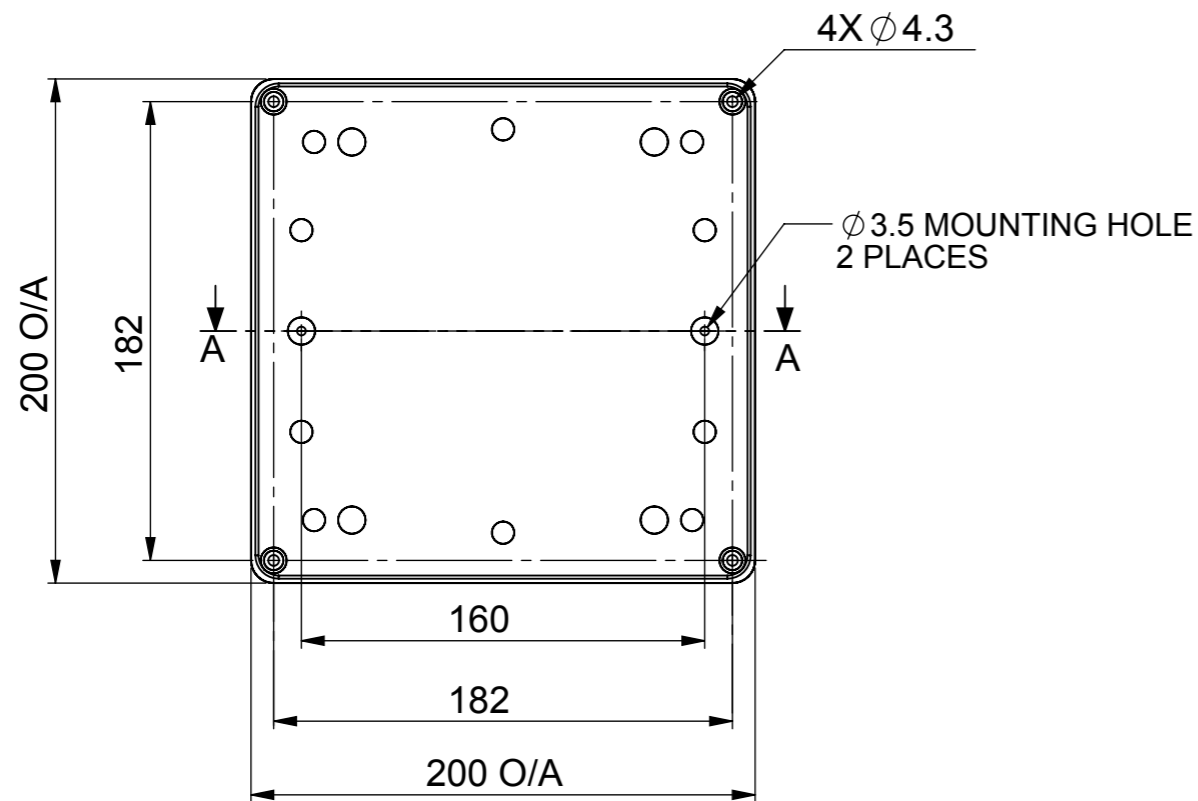

BACK VIEW

ITEM NO.	DESCRIPTION	SHEET NUMBER	MATERIAL	QTY.
8	SCREW M4X6 - PAN HEAD	SHEET 1	ZINC PLATED	4
7	SCREW SELF TAPPING G10X3/8 PAN HEAD	SHEET 1	ZINC PLATED	2
6	MOUNTING BRACKET	SHEET 2	STAINLESS STEEL 1.0mm	2
5	LID SCREW	SHEET 1	POLYCARBONATE (PC)	4
4	MOUNTING PLATE	SHEET 2	GALVANIZED STEEL 1.4mm	1
3	SEAL	SHEET 1	EPDM RUBBER	1
2	LID	SHEET 1	POLYCARBONATE (PC)	1
1	LOWER CASE	SHEET 1	POLYCARBONATE (PC)	1

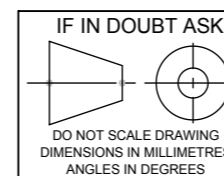

TOLERANCE
UNLESS OTHERWISE SPECIFIED

LINEAR x ± 1
x.x ± 0.5
x.xx ±

ANGULAR x ± 1
x.x ±

ELSEMA

© Copyright
ELSEMA PTY LTD
ABN: 77 001 562 563
31 Tarlington Place
Smithfield NSW 2164
Australia
Telephone (61 2) 9725 1180
Facsimile (61 2) 9725 2663

DRAWN:
L. LI

CHECKED:

APPROVED:

DATE: **06/04/2016**

MATERIAL:	SEE BOM			
FINISH:				
DRAWING TITLE:	CASE C2020-S			
SCALE:	PART No:	DRAWING No:	SHEET No:	REVISION:
A3 1:3	C2020-S	10172	1 of 2	A

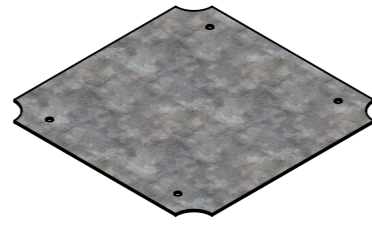

SCALE 1 : 5

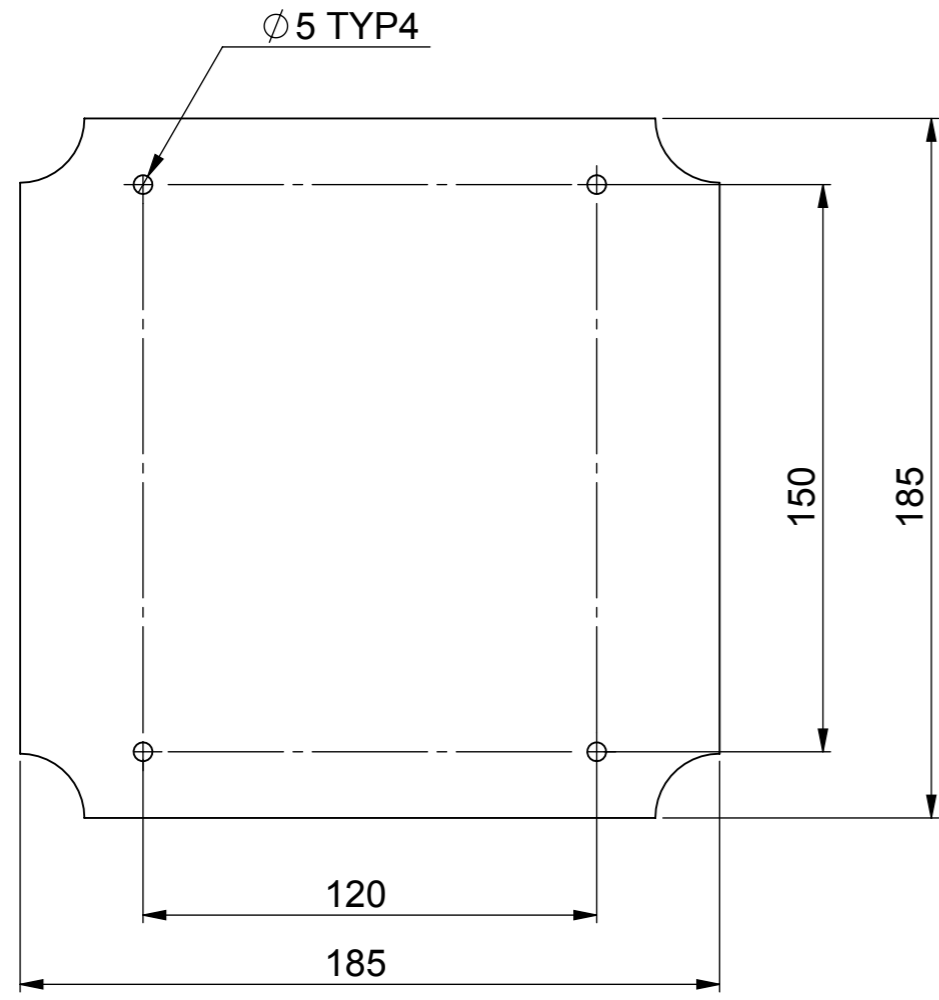

SCALE 1 : 2

ITEM NO.4: MOUNTING PLATE

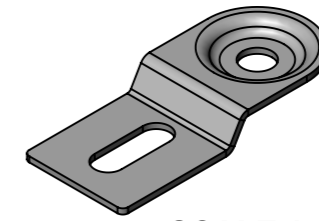

SCALE 1 : 1

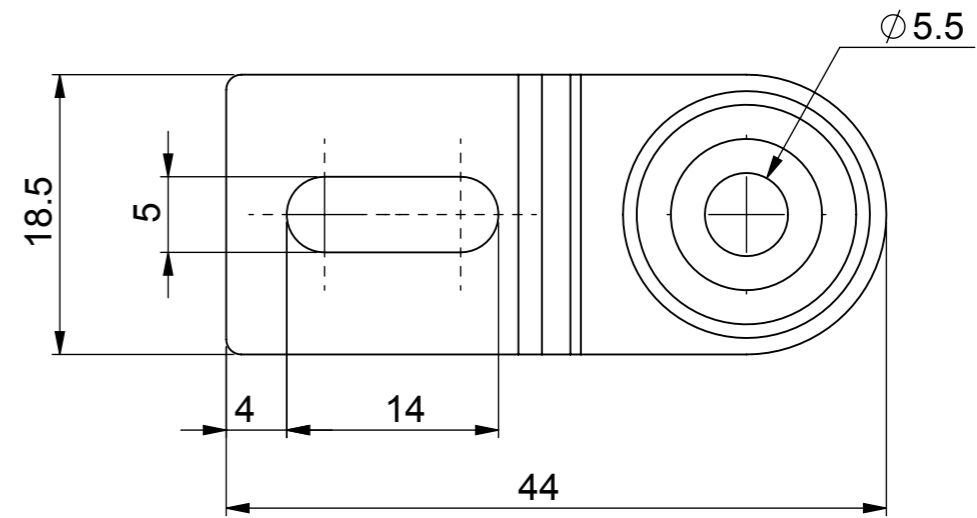
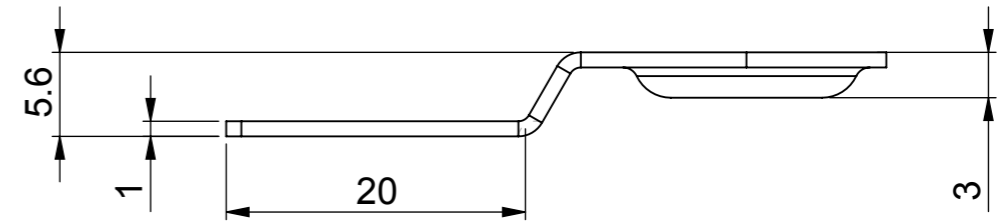

ITEM NO.6: MOUNTING BRACKET

IF IN DOUBT ASK DO NOT SCALE DRAWING DIMENSIONS IN MILLIMETRES ANGLES IN DEGREES	© Copyright ELSEMA PTY LTD ABN: 77 001 562 563 31 Tarlington Place Smithfield NSW 2164 Australia Telephone (61 2) 9725 1180 Facsimile (61 2) 9725 2663		MATERIAL: SEE BOM			
	DRAWN: L. LI		FINISH:			
TOLERANCE UNLESS OTHERWISE SPECIFIED LINEAR x ± 1 x.x ± 0.5 x.xx ± ANGULAR x ± 1 x.x ±		DATE: 06/04/2016		DRAWING TITLE: CASE C2020-S		
CHECKED:		SCALE: A3 2:1	PART No: C2020-S	DRAWING No: 10172	SHEET No: 2 of 2	
APPROVED:		MODEL No:		REVISION: A		